

Number DA0542B	Series TPC500 Locking Devices Polycast 500
-------------------------------------	---

3/8-16 UNC X 1 1/4 LONG ZINC
PLATED HEX HEAD BOLT

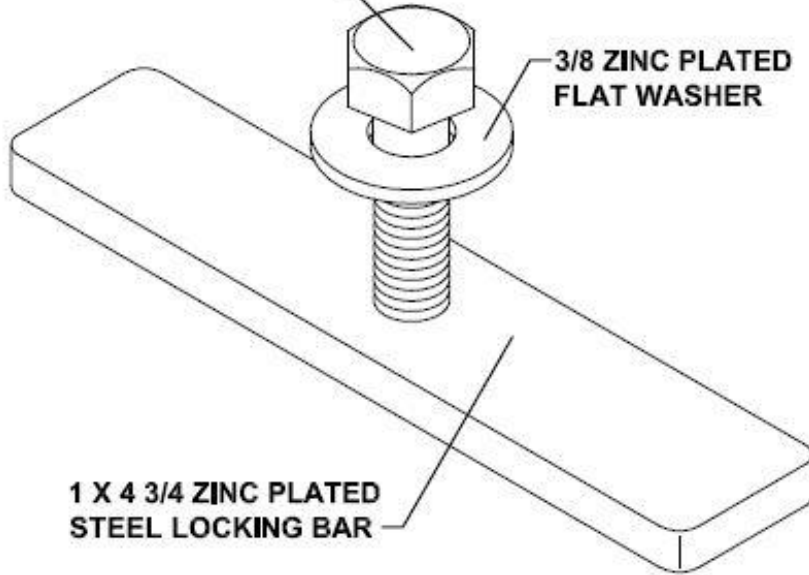

3/8 ZINC PLATED
FLAT WASHER

1 X 4 3/4 ZINC PLATED
STEEL LOCKING BAR

Grate Options (Select One)			
<input checked="" type="checkbox"/>	Grate Type	Part No.	DIN Load Class
<input type="checkbox"/>	Cast Iron Slotted	DG0641	Class C
<input type="checkbox"/>	Ductile Iron Slotted	DG0641D	Class D
<input type="checkbox"/>	Cast Iron Solid (ADA Compliant)	DG0641S	Class D
<input type="checkbox"/>	Ductile Iron Longitudinal Slotted (ADA Compliant)	DG0675HD	Class D

Manufacturer



Specification

POLYCAST 500 SERIES DA0542B LOCKING DEVICES ARE TO BE USED WHERE WHEEL TRAFFIC OCCURS. THIS IS NECESSARY TO PROVIDE SYSTEM INTEGRITY.

DISCLAIMER - The customer and the customer's architects, engineers, consultants, and other professionals are completely responsible for the selection installation and maintenance of any product purchased from Trench Drain Supply and/or its manufacturers. TRENCH DRAIN SUPPLY MAKES NO WARRANTY, EXPRESS OR IMPLIED, AS TO THE SUITABILITY, DESIGN, MERCHANTABILITY, OR FITNESS OF THE PRODUCT FOR CUSTOMERS APPLICATION. The drawing and information provided remain the property and copyright of the manufacturer listed. The manufacturer reserves the right to modify specification without notice.